



MARCH PUMPS

1819 PICKWICK AVE., GLENVIEW, IL 60026-1306, U.S.A
 PHONE: (847) 729-5300 - FAX: (847) 729-7062
 WWW.MARCHPUMP.COM

TE-10K-MD & TE-10P-MD

Model Abbreviations: K: Kynar, P: Polypropylene

DESCRIPTION & OPERATION: Series 10 are centrifugal magnetic drive pumps, eliminating the need for a shaft seal. Pumps are serviceable with an adjustable wrench. Screws should be tightened in sequence & uniformly. Do not over tighten the screws or you may crush the plastic housing bosses. See the parts list for a breakdown of parts. Pumps are not self-priming, lack a suction lift, and thus require a **flooded suction**. Pumps **cannot be run dry** because the impeller requires the liquid being pumped for lubrication. The direction of motor rotation should be clockwise when facing the inlet of the pump. For liquids with a specific gravity greater than water, have a higher viscosity, or for elevated temperatures, a trimmed impeller may be necessary. For application assistance, contact March Pump.

ELECTRICAL: The motor is TEFC (Totally Enclosed Fan Cooled), U.L. listed, rated for continuous duty, and has a conduit box for electrical connections.

CAUTION IN ASSEMBLY & DISASSEMBLY: The magnetic coupling in the pump is strong enough to warrant caution. When servicing the pump, the attraction of the impeller magnet and drive magnet may pull the impeller from your grasp. When assembling, hold onto the outer diameter of the impeller vanes with both hands and gently engage the impeller into the magnet field. Hold the impeller firmly and resist the magnetic attraction as you slowly put the impeller back in. The magnetic forces are strongest between 1/3 to 2/3 of engagement and will diminish when the magnets become aligned. Do not allow the impeller to snap into the rear housing, doing so may result in damage. Exercise caution in placing any of the magnets near steel, tools, or other sensitive instruments as doing so may result in damage or personal injury. When attaching drive magnet to motor shaft, position the face of the drive magnet 3/16 inch above the face of the motor bracket.

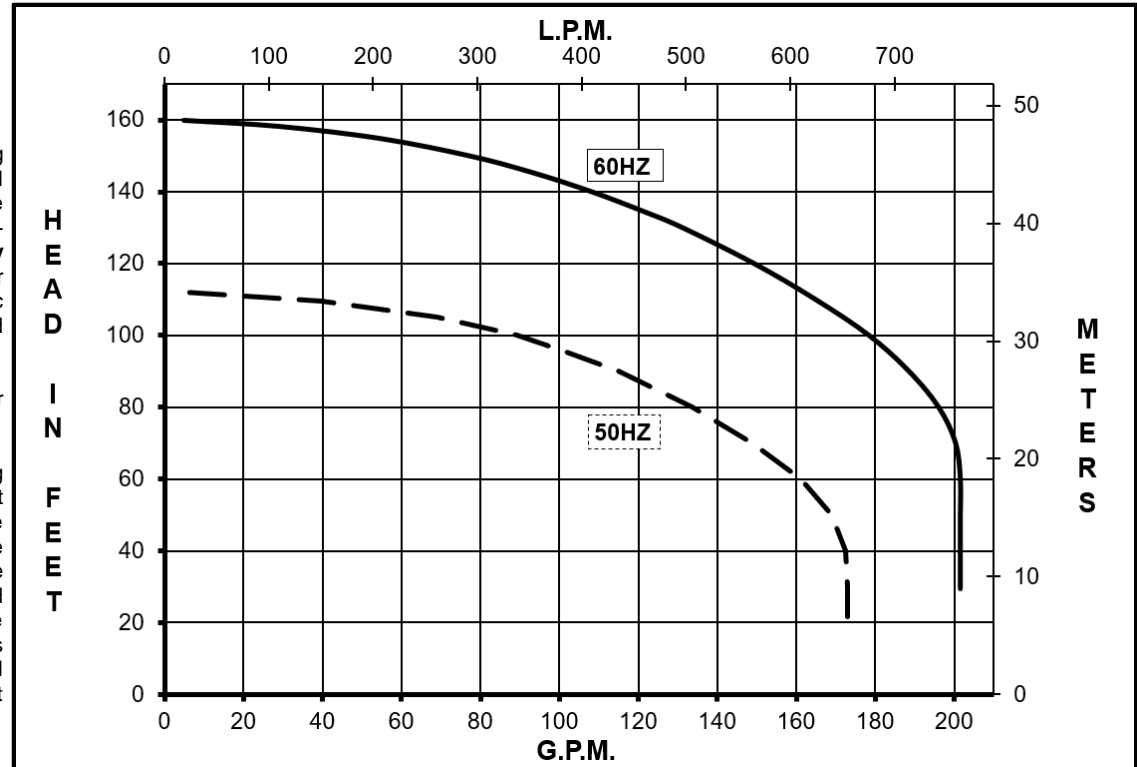

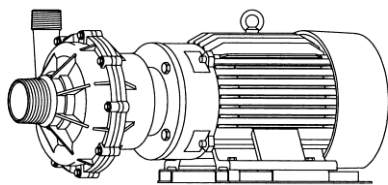
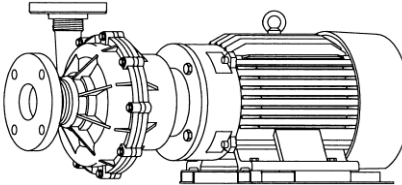
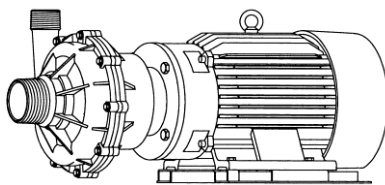
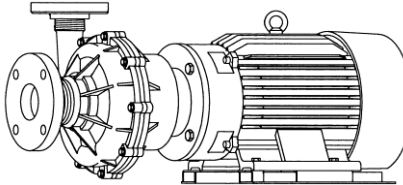
SPECIFICATIONS	TE-10K-MD		TE-10K-MD w/Flanges		TE-10P-MD		TE-10P-MD w/Flanges																							
																														
Product #	0161-0016-0100		0161-0016-0170		0161-0058-0100		0161-0058-0170																							
Inlet – Outlet	3" MPT Inlet x 2" MPT Outlet		3" Flanged Inlet x 2" Flanged Outlet		3" MPT Inlet x 2" MPT Outlet		3" Flanged Inlet x 2" Flanged Outlet																							
Max Internal Pressure	75 psi / 517 kPa		75 psi / 517 kPa		75 psi / 517 kPa		75 psi / 517 kPa																							
Max Liquid Temperature	190 °F / 87 °C		190 °F / 87 °C		190 °F / 87 °C		150 °F / 65 °C																							
MODEL	60 Hz											50 Hz											Height		Width		Length		Packed Weight	
	Max Flow	Max Head	ELECTRICAL									Max Flow	Max Head	ELECTRICAL									Inches	cm	Inches	cm	Inches	cm	lbs	kg
TE-10K-MD TE-10P-MD	gpm	lpm	ft	psi	m	Ph	V	A	Hp	kW	Rpm	gpm	lpm	ft	psi	m	Ph	V	A	Hp	kW	Rpm								
	200	757	160	69.4	48.8	3	230	23.2	10	7.46	3450	172.8	654	112	48.5	34.1	3	380	14.1	10	7.46	2850	13.58	34.49	13.77	34.98	28.70	72.90	255	115.7
TE-10K-MD w/Flange TE-10P-MD w/Flange	200	757	160	69.4	48.8	3	230	23.2	10	7.46	3450	172.8	654	112	48.5	34.1	3	380	14.1	10	7.46	2850	13.92	35.35	13.77	34.98	29.56	75.08	259	117.5

All specifications & data are based on pumping water & are intended as a guideline only. Specifications may vary with different motors.

REPAIR PARTS LIST

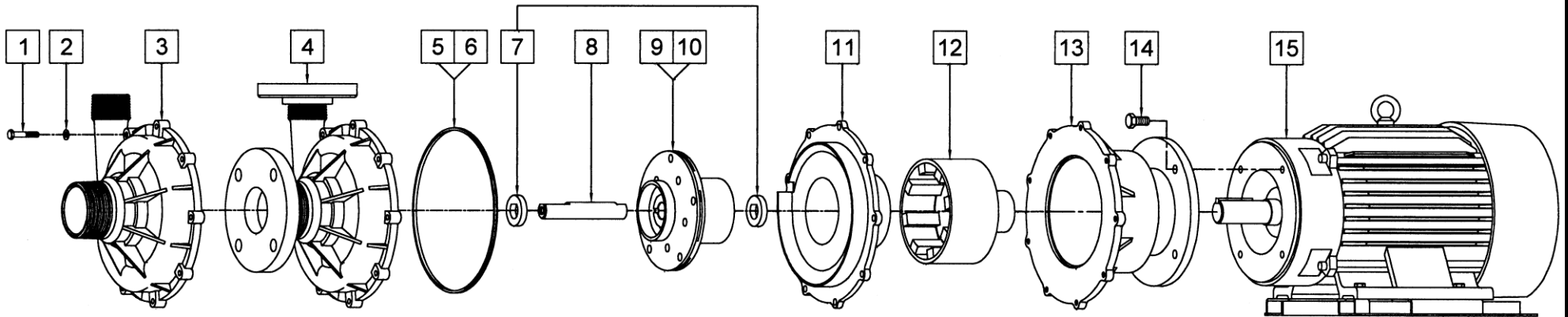

#	TE-10K-MD			#	TE-10P-MD		
1	0160-0029-1000	9	5/16"-18 x 1-3/4" Lg. Screw (Stainless)	1	0160-0029-1000	9	5/16"-18 x 1-3/4" Lg. Screw (Stainless)
2	0160-0030-1000	9	5/16" ID x 5/8" OD Washer (Stainless)	2	0160-0030-1000	9	5/16" ID x 5/8" OD Washer (Stainless)
3	0161-0008-1000	1	Pump Housing (Kynar)	3	0161-0056-1000	1	Pump Housing (Polypropylene)
4	0161-0033-0100	1	Pump Housing w/Flanges (Kynar)	4	0161-0063-0100	1	Pump Housing w/Flanges (Polypropylene)
5	0161-0043-1000	1	9.750" ID x 10" OD Gasket (Viton)	5	0161-0043-1000	1	9.750" ID x 10" OD Gasket (Viton)
6A	0161-0047-1000	1	9.750" ID x 10" OD Gasket (EPDM) – Option	6A	0161-0047-1000	1	9.750" ID x 10" OD Gasket (EPDM) – Option
6B	0161-0059-1000	1	9.750" ID x 10" OD Gasket (Viton/Teflon) – Option	6B	0161-0059-1000	1	9.750" ID x 10" OD Gasket (Viton/Teflon) – Option
7	0161-0001-1000	2	Front & Rear Thrust Washer (Ceramic)	7	0161-0001-1000	2	Front & Rear Thrust Washer (Ceramic)
8	0161-0002-1000	1	Shaft (Ceramic)	8	0161-0002-1000	1	Shaft (Ceramic)
9	0161-0005-0400	1	Impeller w/Carbon Bushings (Kynar)	9	0161-0053-0300	1	Impeller w/Carbon Bushings (Polypropylene)
10	0161-0005-0600	1	Impeller w/Mica Teflon Bushings (Kynar) – Option	10	0161-0053-0400	1	Impeller w/Mica Teflon Bushings (Polypropylene) – Option
11	0161-0009-1000	1	Rear Housing (Kynar)	11	0161-0057-1000	1	Rear Housing (Polypropylene)
12	0161-0031-0100	1	Drive Magnet	12	0161-0031-0100	1	Drive Magnet
13	0161-0007-0010	1	Motor Bracket	13	0161-0007-0010	1	Motor Bracket
14	0160-0031-1000	4	1/2"-13 x 1" Lg. Screw (Stainless)	14	0160-0031-1000	4	1/2"-13 x 1" Lg. Screw (Stainless)
15	0161-0012-1000	1	TEFC Motor, 10 HP, 230/460 V, 3 Phase, 50/60 Hz	15	0161-0012-1000	1	TEFC Motor, 10 HP, 230/460 V, 3 Phase, 50/60 Hz
W	0161-0035-0100	1	Wet End Kit (Items: 1, 2, 3, 5, 7, 8, 9, 11)	W	0161-0060-0100	1	Wet End Kit (Items: 1, 2, 3, 5, 7, 8, 9, 11)
Materials in Contact with Solution				Materials in Contact with Solution			
Kynar/Carbon Filled, Ceramic, Viton, & Carbon				Polypropylene, Ceramic, Viton, & Carbon			

LIMITED WARRANTY

March pumps are guaranteed only against defects in workmanship or materials for a period of one year from date of manufacture pumping water. For the complete warranty and to register online go to: www.marchpump.com/warranty-registration

Explosion proof and special voltage motors are available upon special order.

NOTE: Contact Factory for other materials and/or parts not listed.

0161-0018-1000 R17